

Poolside Gate Assembly and Installation

Assembly

Poolside gates are generally 1.2m high and 0.935m wide. Other width gates can easily be made by increasing or decreasing the number of vertical bars and cutting the rail and pool channel lengths to suit.

NOTE: Standard Tru-close hinges are suitable for gates 1.2 high x 1.2 wide. Heavy duty Tru-close hinges are recommended for larger gates.

Components -

Gate stile	2
Rail	2 (cut from full rail)
19mm square bars	7
Pool channel	2 (cut from full channel)
50mm square black cap	4
50mm square posts	1@ 2.1m, 1@1.8m
Tek screws painted	24
Magna Latch	1
Tru-close hinge	1 pair

PLEASE NOTE WHEN CUTTING COLORSTEEL USE A HACKSAW OR TINSNIPS. DO NOT USE AN ANGLE GRINDER OR ABRASIVE CUTOFF BLADES.

Step 1 - Cut rails to length using a hacksaw. Rails should be cut to the desired width of gate less 102mm. Ensure this cut is square and file burrs off. Wipe swarf off with a soft cloth.

Step 2 - Cut the pool channel to the same length as the rails using a hacksaw or tinsnips. Ensure the amount trimmed is the same each end. Wipe swarf off with a soft cloth.

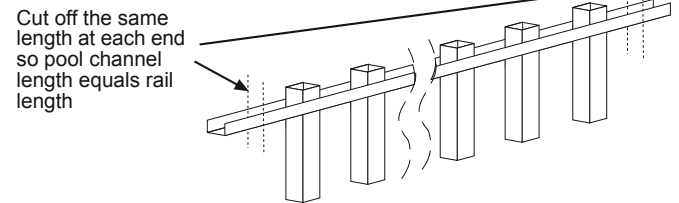

Step 3 - Assemble panel as per Instruction Sheet P1. Secure top and bottom pool channel to 19mm square vertical bars with 3 Tek screws equally spaced.

Step 4 - Assemble stiles, rails and panel then tek screw rail to gate stile channel, using 4 tek screws per corner as shown in the diagram.

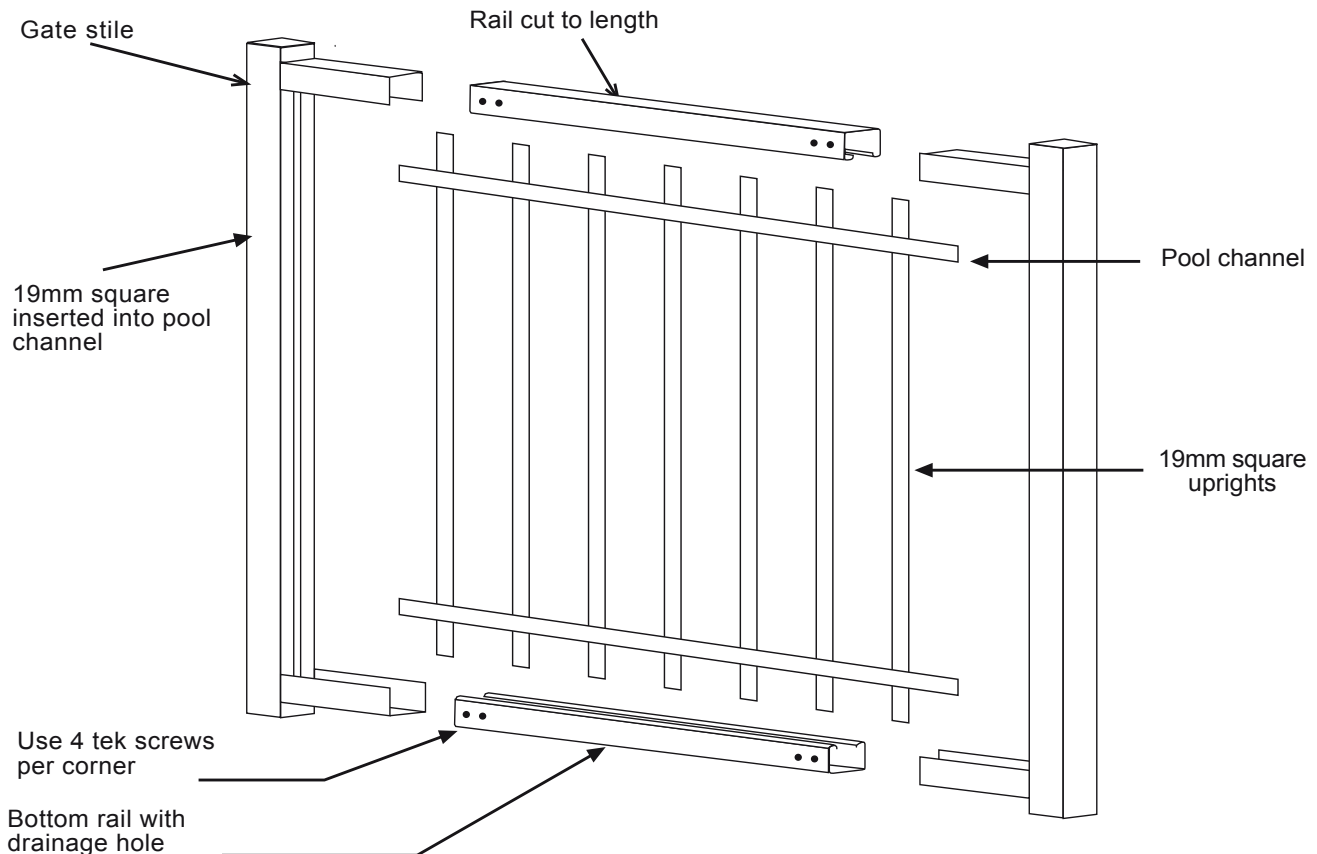

Poolside Gate Assembly and Installation Continued

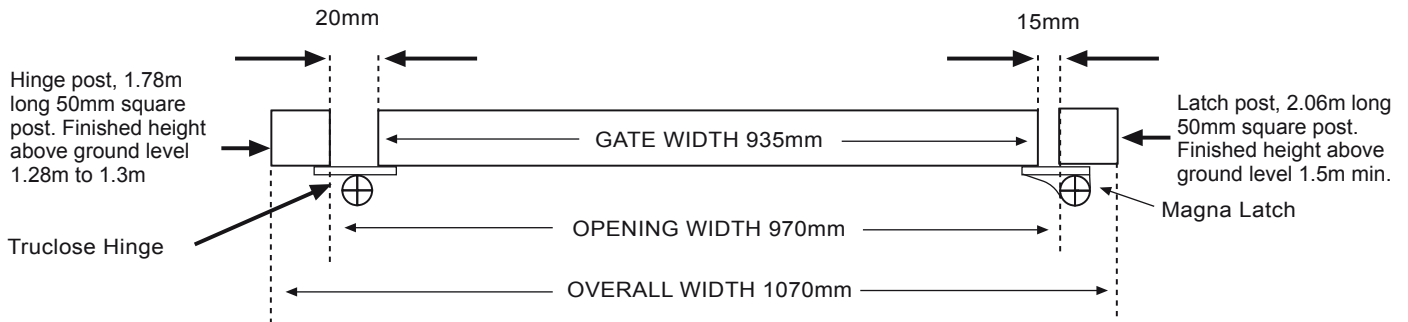

Remember the gate is to open away from the pool. Decide which side to concrete or bolt down the hinge and latch posts.

Installation

Step 1 - Concrete in gate posts while installing fencing. Be sure to set posts vertical using a good level. Make sure gaps are correct, and you have set the latch and hinge posts on the correct side (see diagram at the bottom of the page). Make sure tops of posts are correct heights above the ground. Hang the gate the following day.

Step 2 - Fix hinges to your gate first. Tek screw these on at approx. 100mm from the top and 100mm from the bottom.

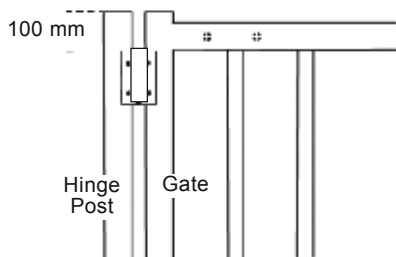

Step 3 - Fix the gate to the hinge post. Support the gate on blocks so that the gate is level with the top of the hinge post. Check the gap under the gate is not greater than 100mm. Now tek screw the hinges to the hinge post. The hinge will automatically set the gap to 20mm provided it is pushed firmly against the hinge post when tek screwing.

Step 4 - Fix the Magna Latch on the outside of the higher gate latch post. ie: away from the pool enclosure. Follow the instructions on the Magna Latch pack.

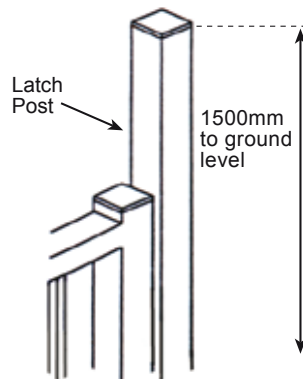

Step 5 - Adjust the Truclose Hinges. Clause F9 of the NZ Building Code requires the pool gate to shut automatically from any position.

Your Truclose hinges have a tension spring built inside to ensure your gate will self shut. Simply follow the instructions in the Truclose pack.